

# PROVIDE PROFESSIONAL GALVO SCANNING SOLUTIONS

提供专业振镜  
扫描解决方案



**HAN'S SCANNER**  
**大族思特**



# CONTENTS

## 目录

01. 公司简介 Introduction	02	
02. 振镜电机 Galvanometer	03/07	
03. 扫描头 Scanner	08/18	
04. 智能一体扫描系统 Intelligent integrated scanning system	19/20	
05. 高功率振镜焊接系统 High Power Galvanometer Welding System	21/22	
06. 音圈电机 Voice Motor	23/24	
		07. 三维动态大幅面调焦系统 25/29 3D Large Field size Dynamic Focusing System
		08. 四轴联动系统 30/31 Four-axis linkage system
		09. 五轴微加工系统 32 5 axis Micromachining System
		10. 棱镜面扫描头 33/34 Polygon Scan Head
		11. 光学相干断层扫描 35/36 Optical Coherence Tomography Scan
		12. 医疗美容点阵系统 37/38 Medical beauty Fractional Galvanometer

# INTRODUCTION

## 公司简介



深圳市大族思特科技有限公司，是一家集技术研究、开发、生产和销售为一体的高科技企业，属于上市公司—大族激光科技产业集团股份有限公司的全资控股子公司，位于深圳市福永大族生产基地工业园。

本公司拥有专业的机械、软件、光学、电子、工艺测试等研发团队，拥有多项实用新型及发明专利和软件著作权，除了研发标准振镜产品和打标控制卡，还为客户提供定制化的振镜系统扫描解决方案。现产品有系列化的光电数字振镜系统、系列化的光栅数字振镜系统、音圈电机、智能一体扫描系统、三维动态大幅面调焦系统、激光面扫描、光学相干断层扫描和医疗点阵系统等。

国内首建流水线式振镜生产线，振镜扫描系统年产量可高达四万套；扫描头和振镜系统解决方案已成功应用于手机3C行业、精密加工、焊接、切割、激光演示、3D打印、食品包装、烟草行业以及医疗技术等领域。

Shenzhen Han's Scanner S&T Co., Ltd. is a high-tech company that integrates technology research& development, production and sales. It is a wholly owned subsidiary of Han's Laser Technology Industry Group Co., Ltd, the listed company, located in Shenzhen HAN'S Laser Industrial Park, China.

Han's Scanner has professional R&D Team on machinery, software, optics, electronics, process testing, etc. We also have a number of utility models patents, invention patents and software copyrights. Except providing regular galvanometer and control cards, we also provide customized scan solution for our clients. The current products include serialized photoelectric galvanometer system, serialized rating galvanometer system, voice motor, smart integrated scanning system, 3D large field size dynamics focusing system, High-Speed Polygon Scanner Systems, OCT scanner system and medical scanner system, etc.

Han's Scanner is the pioneer of pipelined production for galvanometer products in China, and the annual capacity reaches up to 40,000 sets. Our scanner system solutions have been successfully applied to the mobile 3C industry, food packaging, tobacco industry and medical technology, etc.



# GALVANOMETER MOTOR

## 振镜电机

### 电机结构

#### MOTOR STRUCTURE

单轴振镜电机包含高精度传感器和基于移动磁铁技术的电机部分。电机转子经过优化设计，有极佳的动态属性和响应特性，此外，电机具有高刚性和低摩擦的特点。另外通过运动学和动力学仿真，针对每个电机都匹配了一定惯量的镜片。

The single-axis galvanometer motor contains a high-precision sensor and a motor part based on moving magnet technology. The motor rotor is optimized for excellent dynamic properties and response characteristics. In addition, the motor features high rigidity and low friction. Moreover, each motor is matched to a certain inertia mirror through the kinematics and dynamics simulation.

### 光电振镜

#### ULTRA-GALVO

用光电传感器作为反馈系统的振镜，特点是具有较高的重复精度和线性度，而且性价比极高。

Configured photoelectric sensor as feedback, it has high repeatability and linearity with high performance to cost ratio.

### 光栅振镜

#### EXTRA-GALVO

用光栅编码器作为反馈系统的振镜，对比光电振镜，具有更高的位置解析度、更好的重复性和更低的漂移，即使在环境温度变化的条件下，也保持较好的重复性。

Configured grating encoder as feedback, it has higher position resolution, better repeatability and lower drift compared with photoelectric galvanometer. Even if under the temperature variation, it maintains good repeatability.

### 传感器对比

#### SENSOR COMPARISON

		Ultra-Galvo	Extra-Galvo
最大角度	Maximum Angle (°)	±12.5	±12.5
非线性度	Nonlinearity (%)	< 0.4	< 0.1
重复精度	Repeatability (μrad)	< 5	< 2
零位漂移	Offset Drift (μrad/K)	< 15	< 15
增益漂移	Gain Drift (ppm/K)	< 50	< 8
位置解析度	Position Resolution	18位 Bit	23位 Bit

# ULTRA-GALVO

## 光电振镜



### □ 技术参数

TECHNICAL PARAMETERS

ULTRA-GALVO		XXXS	XXS	XS	S	M	L	XL
入口光斑	Input Beam Aperture (mm)	< 7	7	8.5	10	14	20-30	50-80
转动惯量	Moment Of Inertia (g·cm <sup>2</sup> )	0.013	0.018	0.174	0.34	1.2	5.1	14.3
力常数	Force Constant (N·mm/A)	1.2	2.7	5.3	7.5	15	24	35
线圈电阻	Coil Resistance (Ω)	2.1	3.6	2.1	2.7	2.6	1.58	0.9
线圈电感	Coil Inductance (μH)	35	70	63.5	165	275	300	343
最大连续电流	Maximum Continuous Current (A)	2.3	2.3	2.3	2.5	3.5	5	7
峰值电流	Peak Current (A)	6	8	10	10	10	10	10
上升时间	Rise Time (ms)	0.13	0.1	0.15	0.18	0.3	0.7	1.5
质量	Weight (g)	13	18	50	220	300	400	460

### □ 外形尺寸图

TECHNICAL DRAWING

UltraGalvo < 7mm

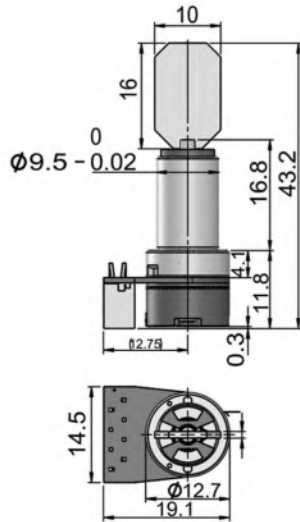
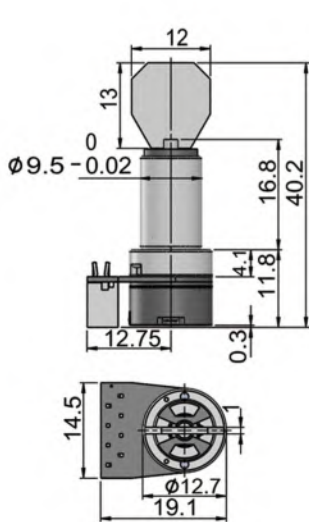

UltraGalvo 7mm

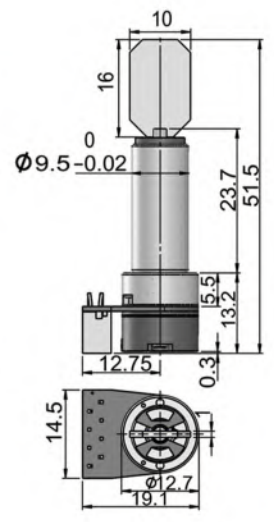
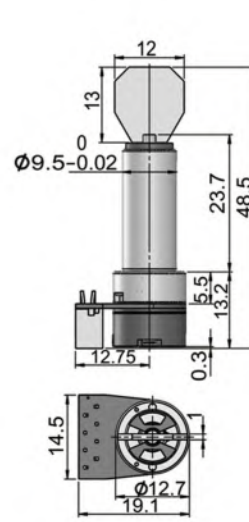

□ 外形尺寸图  
TECHNICAL DRAWING

UltraGalvo 8.5mm

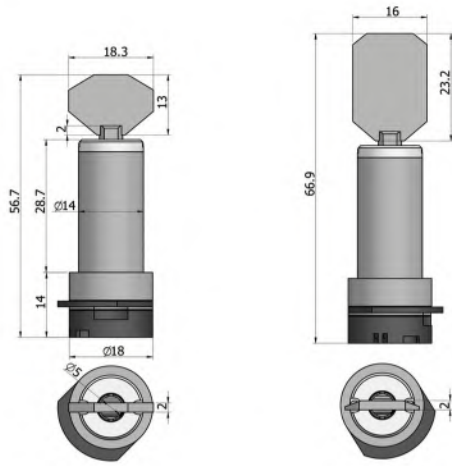

UltraGalvo 10mm

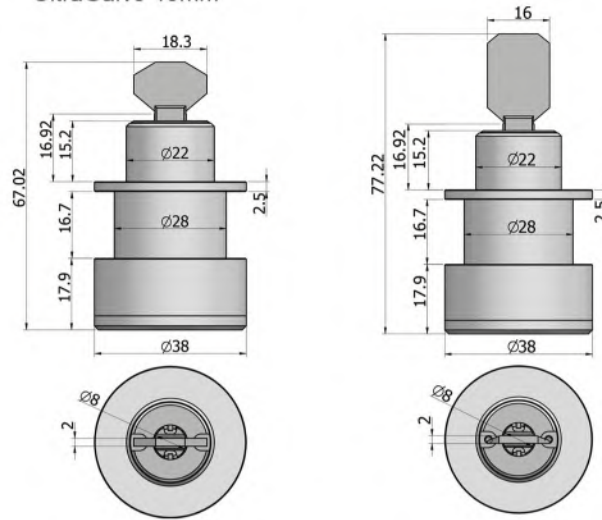

UltraGalvo 14mm

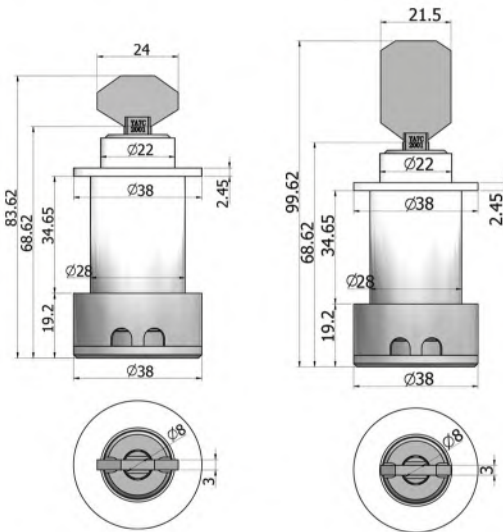

UltraGalvo 20mm

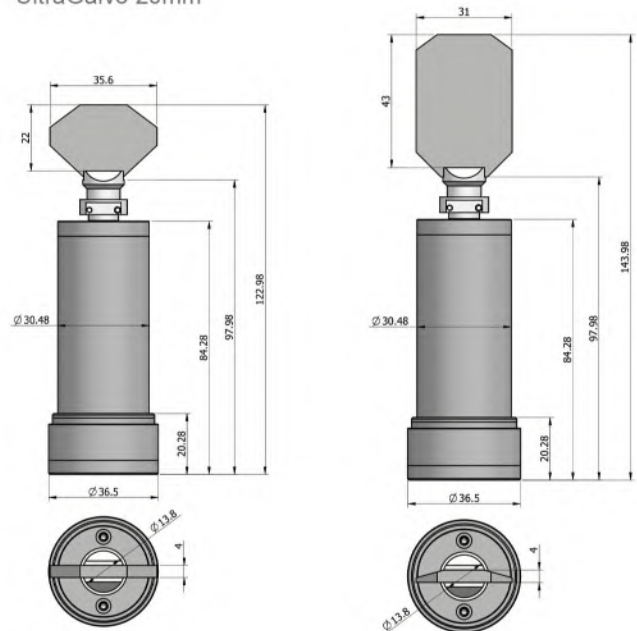

UltraGalvo 30mm

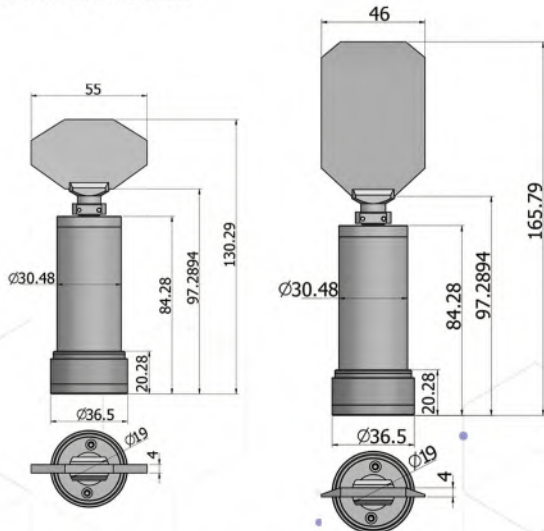

UltraGalvo 50mm

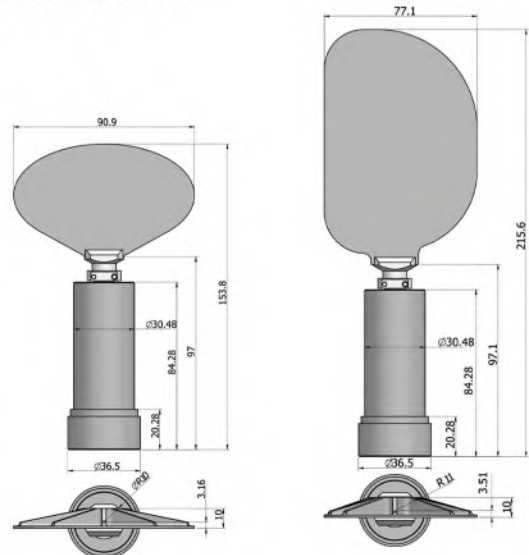



# EXTRA-GALVO

## 光栅振镜



### □ 技术参数

TECHNICAL PARAMETERS

EXTRA-GALVO		S	M	L
入口光斑	Input Beam Aperture (mm)	10	14	20-30
转动惯量	Moment Of Inertia (g·cm <sup>2</sup> )	0.6	1.5	7.2
力常数	Force Constant (N·mm/A)	7.5	15	24
线圈电阻	Coil Resistance (Ω)	2.7	2.6	1.58
线圈电感	Coil Inductance (μH)	155	275	385
最大连续电流	Maximum Continuous Current (A)	2.5	3.5	5
峰值电流	Peak Current (A)	10	10	10
上升时间	Rise Time (ms)	0.2	0.3	0.7
质量	Weight (g)	220	300	400

### □ 外形尺寸图

TECHNICAL DRAWING

ExtraGalvo 10mm

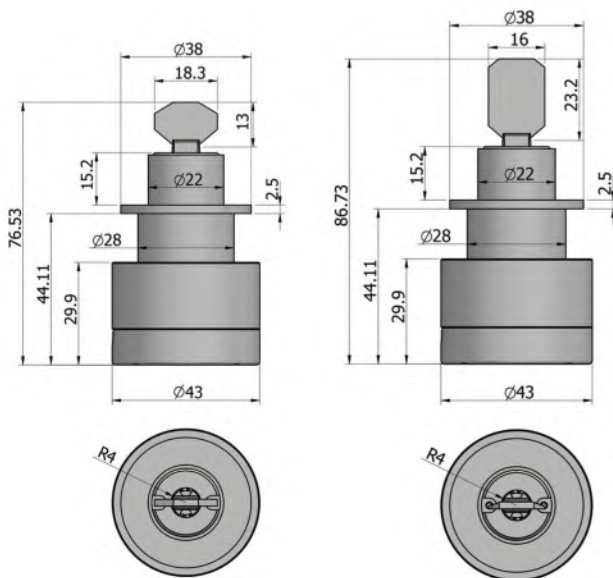

ExtraGalvo 14mm

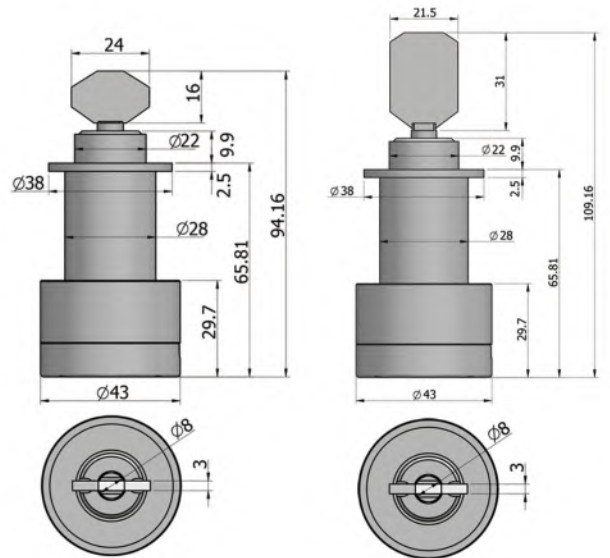

外形尺寸图  
TECHNICAL DRAWING

ExtraGalvo 20mm

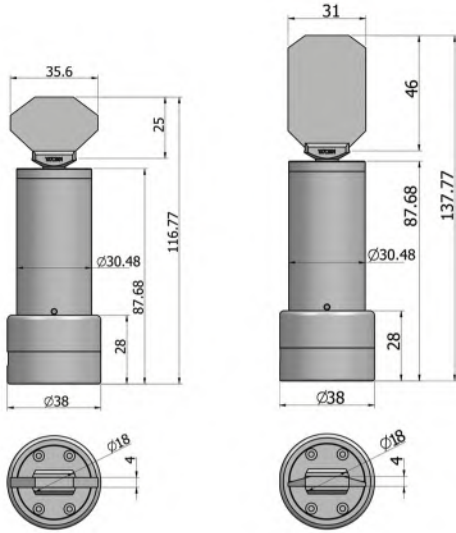

ExtraGalvo 30mm

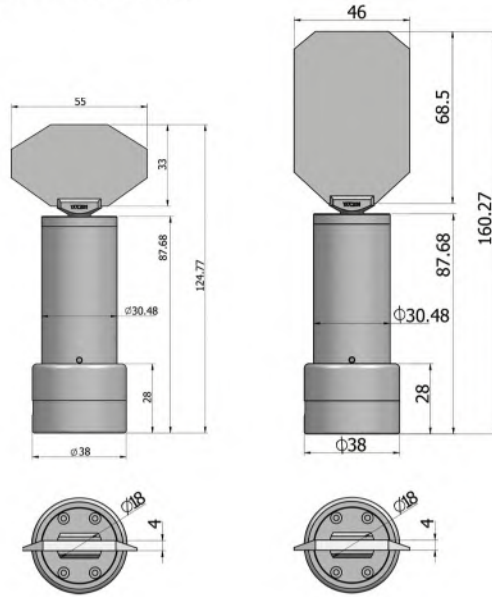

驱动器  
DRIVER



数字驱动器  
Digital Driver



模拟驱动器  
Analog Drive





# SCANNER

## 扫描头

### 产品特点

FEATURES



低噪声、高线性度和低漂移。  
Low noises, high linearity and low drift.



可以适配多种F-theta镜头。  
Support varieties of F-theta lenses.



模块化设计，易于安装维护。  
Modular design, easy installment and maintenance.



标准协议为:XY2-100，也可选其他协议。  
Available to general protocol (XY2-100) and other protocols.

### 行业应用

INDUSTRY APPLICATIONS

可应用于非金属和部分金属材料加工，现广泛应用于多个领域，如食品包装、饮料包装、医药包装、建筑陶瓷、钮扣、工艺礼品、电子元件、手机外壳、笔记本及平板外壳、剥线、薄膜切割、PCB条码、外壳铭牌等领域。

Our scanner systems can process non-metallic and partial metallic materials. It is widely used in many industries, such as food packaging, beverage packaging, pharmaceutical packaging, architectural ceramics, buttons, craft gifts, electronic components, mobile phone casings, notebook and flat casing, stripping, film cutting, PCB bar code, shell nameplate, etc.

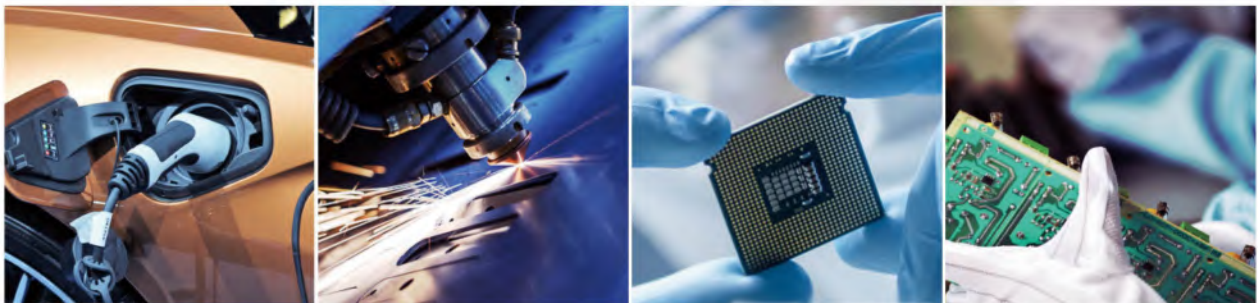



# ULTRASCAN 7MM

## 7mm光电振镜

### □ 技术参数

#### TECHNICAL PARAMETERS

UltraScan 7mm		
入口光斑	Input Beam Aperture (mm)	7
光柱位移	Beam Displacement (mm)	9.98
跟随误差	Tracking Error (ms)	0.12
重复精度	Repeatability (μrad)	< 2
零位漂移	Offset Drift (μrad/K)	< 20
增益漂移	Gain Drift (ppm/K)	< 100
8小时以上漂移	Long-term drift over 8 hours (mrad)	< 0.4
1%全行程	1% of full scale (ms)	0.19
10%全行程	10% of full scale (ms)	0.6
定位速度	Positioning Speed (m/s)	24
扫描角度	Typical Scan Angle (°)	±20
增益误差	Gain Error (mrad)	< 5
零位误差	Zero Offset (mrad)	< 5
非线性度	Nonlinearity (%)	< 0.4
电源要求	Power Requirements	±15VDC, ≥3A
数字接口	Digital Interface	XY2-100
工作温度	Operation Temperature (°C)	25±10
重量	Weight (kg)	1.6

### □ 外形尺寸图

#### TECHNICAL DRAWING

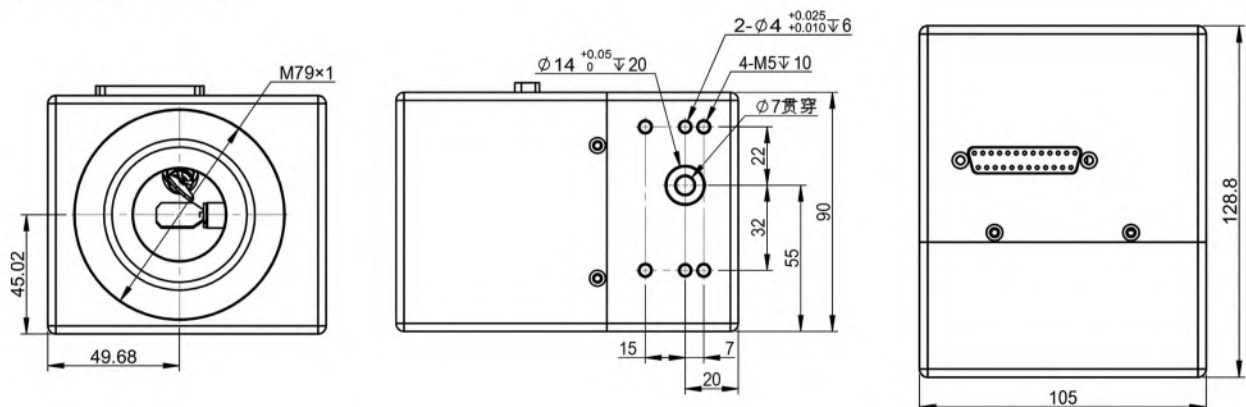



# ULTRASCAN 10MM

## 10mm光电振镜



### □ 技术参数

TECHNICAL PARAMETERS

		UltraScan I-精密打标 Precision Marking	UltraScan I - 飞行打标 Marking-on-the-fly	UltraScan I -FPC 及SLA FPC And SLA Applications	UltraScan II
入口光斑	Input Beam Aperture (mm)	10	10	10	10
光柱位移	Beam Displacement (mm)	12.54	12.54	12.54	12.54
跟随误差	Tracking Error (ms)	0.18	0.14	0.16	0.16
重复精度	Repeatability ( $\mu$ rad)	< 2	< 3	< 2	< 2
零位漂移	Offset Drift ( $\mu$ rad/K)	< 15	< 15	< 15	< 12
增益漂移	Gain Drift (ppm/K)	< 80	< 80	< 80	< 50
8小时以上漂移	Long-term drift over 8 hours (mrad)	< 0.3	< 0.4	< 0.15	< 0.15
1%全行程	1% of full scale (ms)	0.40	0.30	0.35	0.35
10%全行程	10% of full scale (ms)	1.20	1.00	1.10	1.15
定位速度	Positioning Speed (m/s)	10.0	20.0	15.0	11.0
扫描角度	Typical Scan Angle ( $^{\circ}$ )	$\pm 12.5$	$\pm 12.5$	$\pm 12.5$	$\pm 12.5$
增益误差	Gain Error (mrad)	< 5	< 5	< 5	< 5
零位误差	Zero Offset (mrad)	< 5	< 5	< 5	< 5
非线性度	Nonlinearity (%)	< 0.4	< 0.4	< 0.4	< 0.4
电源要求	Power Requirements	$\pm 15$ VDC, $\geq 3$ A	$\pm 15$ VDC, $\geq 3$ A	$\pm 15$ VDC, $\geq 3$ A	$\pm 15$ VDC, $\geq 3$ A
数字接口	Digital Interface	XY2-100	XY2-100	XY2-100	XY2-100
工作温度	Operation Temperature ( $^{\circ}$ C)	25 $\pm$ 10	25 $\pm$ 10	25 $\pm$ 10	25 $\pm$ 10
重量	Weight (kg)	1.9	1.9	1.9	1.9

### □ 外形尺寸图

TECHNICAL DRAWING

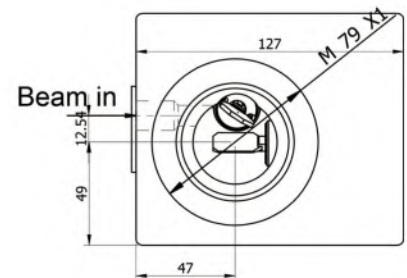
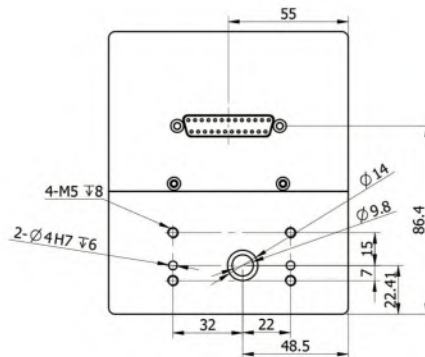
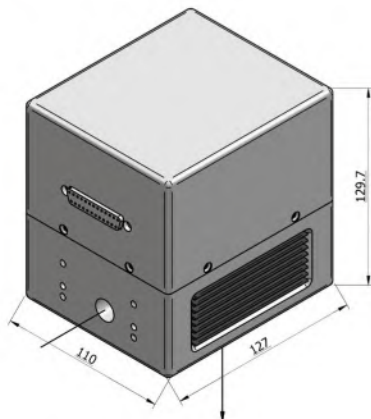



# ULTRASCAN 14MM

## 14mm光电振镜

### □ 技术参数

TECHNICAL PARAMETERS



		UltraScan I 14mm	UltraScan II 14mm
入口光斑	Input Beam Aperture (mm)	14	14
光柱位移	Beam Displacement (mm)	16.42	16.42
跟随误差	Tracking Error (ms)	0.30	0.25
重复精度	Repeatability ( $\mu$ rad)	< 2	< 2
零位漂移	Offset Drift ( $\mu$ rad/K)	< 15	< 12
增益漂移	Gain Drift (ppm/K)	< 80	< 50
8小时以上漂移	Long-term drift over 8 hours (mrad)	< 0.3	< 0.15
1%全行程	1% of full scale (ms)	0.65	0.6
10%全行程	10% of full scale (ms)	1.60	1.5
定位速度	Positioning Speed (m/s)	7.0	8.0
扫描角度	Typical Scan Angle ( $^{\circ}$ )	$\pm 12.5$	$\pm 12.5$
增益误差	Gain Error (mrad)	< 5	< 5
零位误差	Zero Offset (mrad)	< 5	< 5
非线性度	Nonlinearity (%)	< 0.4	< 0.4
电源要求	Power Requirements	$\pm 15$ VDC, $\geq 3$ A	$\pm 15$ VDC, $\geq 3$ A
数字接口	Digital Interface	XY2-100	XY2-100
工作温度	Operation Temperature ( $^{\circ}$ C)	25 $\pm$ 10	25 $\pm$ 10
重量	Weight (kg)	2.3	2.3

### □ 外形尺寸图

TECHNICAL DRAWING

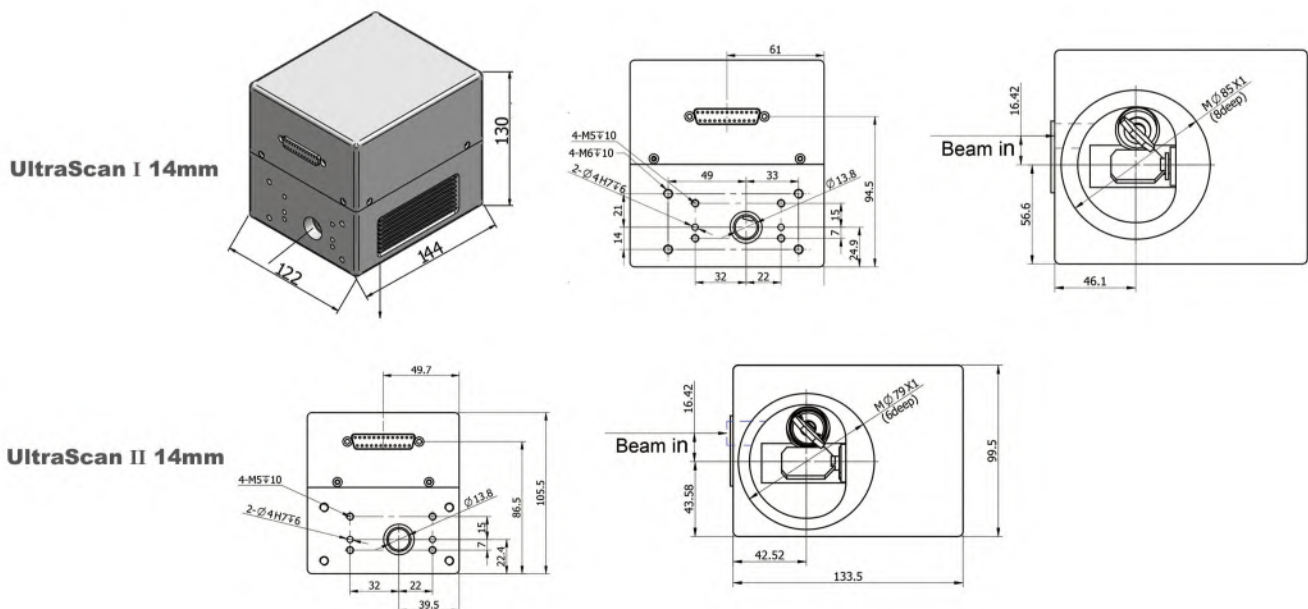

# ULTRASCAN 20MM

## 20mm光电振镜



### □ 技术参数

#### TECHNICAL PARAMETERS

		UltraScan I 20mm	UltraScan II 20mm
入口光斑	Input Beam Aperture (mm)	20	20
光柱位移	Beam Displacement (mm)	25.25	25.25
跟随误差	Tracking Error (ms)	0.45	0.35
重复精度	Repeatability ( $\mu$ rad)	< 2	< 2
零位漂移	Offset Drift ( $\mu$ rad/K)	< 15	< 12
增益漂移	Gain Drift (ppm/K)	< 80	< 50
8小时以上漂移	Long-term drift over 8 hours (mrad)	< 0.3	< 0.15
1%全行程	1% of full scale (ms)	0.80	0.70
10%全行程	10% of full scale (ms)	2.50	2.40
定位速度	Positioning Speed (m/s)	5.0	6.0
扫描角度	Typical Scan Angle ( $^{\circ}$ )	$\pm 12.5$	$\pm 12.5$
增益误差	Gain Error (mrad)	< 5	< 5
零位误差	Zero Offset (mrad)	< 5	< 5
非线性度	Nonlinearity (%)	< 0.4	< 0.4
电源要求	Power Requirements	$\pm 15$ VDC, $\geq 3$ A	$\pm 15$ VDC, $\geq 3$ A
数字接口	Digital Interface	XY2-100	XY2-100
工作温度	Operation Temperature ( $^{\circ}$ C)	$25 \pm 10$	$25 \pm 10$
重量	Weight (kg)	5.0	5.0

### □ 外形尺寸图

#### TECHNICAL DRAWING

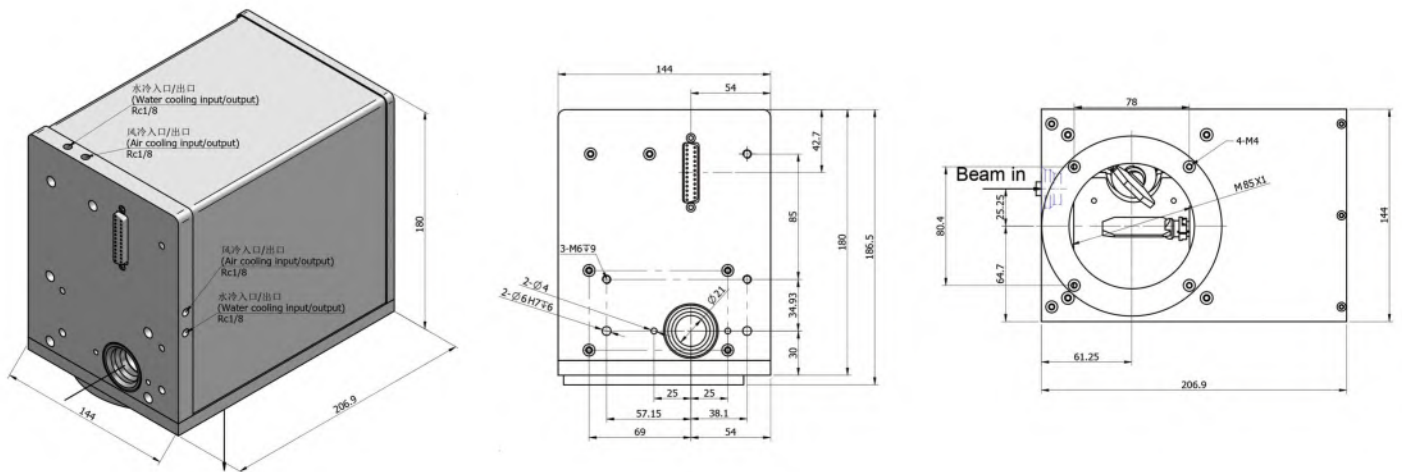



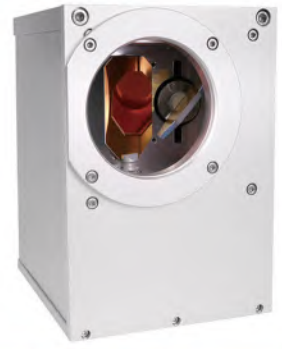

# ULTRASCAN 30MM

## 30mm光电振镜

### □ 技术参数

#### TECHNICAL PARAMETERS

		UltraScan I 30mm	UltraScan II 30mm
入口光斑	Input Beam Aperture (mm)	30	30
光柱位移	Beam Displacement (mm)	35.61	35.53
跟随误差	Tracking Error (ms)	0.70	0.6
重复精度	Repeatability (μrad)	< 2	< 2
零位漂移	Offset Drift (μrad/K)	< 15	< 12
增益漂移	Gain Drift (ppm/K)	< 80	< 50
8小时以上漂移	Long-term drift over 8 hours (mrad)	< 0.3	< 0.15
1%全行程	1% of full scale (ms)	1.20	1.10
10%全行程	10% of full scale (ms)	4.50	4.40
定位速度	Positioning Speed (m/s)	3.0	4.0
扫描角度	Typical Scan Angle (°)	±12.5	±12.5
增益误差	Gain Error (mrad)	< 5	< 5
零位误差	Zero Offset (mrad)	< 5	< 5
非线性度	Nonlinearity (%)	< 0.4	< 0.4
电源要求	Power Requirements	±15VDC, ≥3A	±15VDC, ≥3A
数字接口	Digital Interface	XY2-100	XY2-100
工作温度	Operation Temperature (°C)	25±10	25±10
重量	Weight (kg)	5.2	5.2

### □ 外形尺寸图

#### TECHNICAL DRAWING

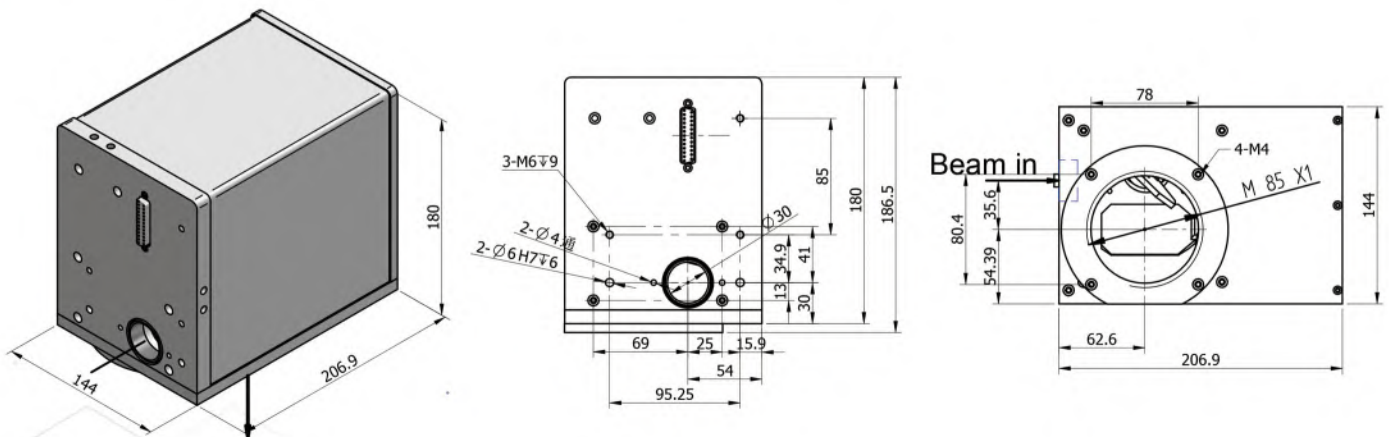



# ULTRASCAN 50MM

## 50mm光电振镜



### □ 技术参数

#### TECHNICAL PARAMETERS

UltraScan 50mm		
入口光斑	Input Beam Aperture (mm)	50
光柱位移	Beam Displacement (mm)	62.25
跟随误差	Tracking Error (ms)	1
重复精度	Repeatability (μrad)	< 2
零位漂移	Offset Drift (μrad/K)	< 15
增益漂移	Gain Drift (ppm/K)	< 80
8小时以上漂移	Long-term drift over 8 hours (mrad)	< 0.3
1%全行程	1% of full scale (ms)	1.5
10%全行程	10% of full scale (ms)	6.5
定位速度	Positioning Speed (m/s)	1
扫描角度	Typical Scan Angle (°)	±12.5
增益误差	Gain Error (mrad)	< 5
零位误差	Zero Offset (mrad)	< 5
非线性度	Nonlinearity (%)	< 0.4
电源要求	Power Requirements	±15VDC, ≥3A
数字接口	Digital Interface	XY2-100
工作温度	Operation Temperature (°C)	25±10
重量	Weight (kg)	8.8

### □ 外形尺寸图

#### TECHNICAL DRAWING

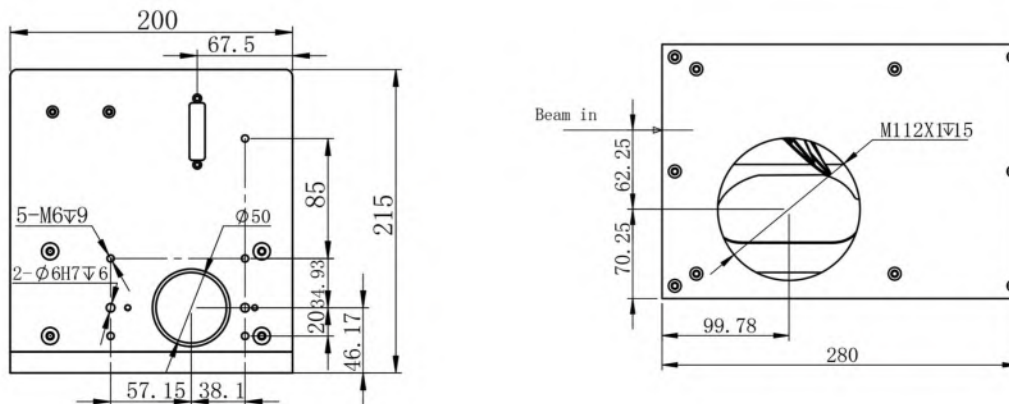

# EXTRASCAN 10MM

## 10mm光栅振镜



### □ 技术参数

TECHNICAL PARAMETERS

		ExtraScan I 10mm	ExtraScan II 10mm
入口光斑	Input Beam Aperture (mm)	10	10
光柱位移	Beam Displacement (mm)	12.54	12.54
跟随误差	Tracking Error (ms)	0.3	0.2
重复精度	Repeatability ( $\mu$ rad)	< 1	< 1
零位漂移	Offset Drift ( $\mu$ rad/K)	< 15	< 15
增益漂移	Gain Drift (ppm/K)	< 8	< 8
8小时以上漂移	Long-term drift over 8 hours (mrad)	< 0.1	< 0.08
1%全行程	1% of full scale (ms)	0.55	0.45
10%全行程	10% of full scale (ms)	1.4	1.30
定位速度	Positioning Speed (m/s)	7	10.0
扫描角度	Typical Scan Angle ( $^{\circ}$ )	$\pm 12.5$	$\pm 12.5$
增益误差	Gain Error (mrad)	< 5	< 5
零位误差	Zero Offset (mrad)	< 5	< 5
非线性度	Nonlinearity (%)	< 0.1	< 0.1
电源要求	Power Requirements	$\pm 15$ VDC, $\geq 3$ A	$\pm 15$ VDC, $\geq 3$ A
数字接口	Digital Interface	XY2-100	XY2-100
工作温度	Operation Temperature ( $^{\circ}$ C)	25 $\pm$ 10	25 $\pm$ 10
重量	Weight (kg)	1.9	1.9

### □ 外形尺寸图

TECHNICAL DRAWING

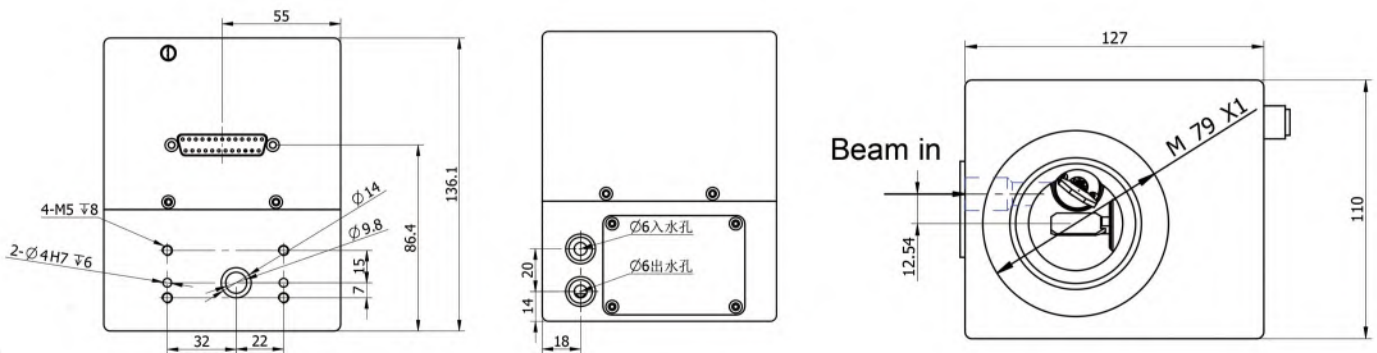

# EXTRASCAN 14MM

## 14mm光栅振镜



### □ 技术参数

TECHNICAL PARAMETERS

		ExtraScan I 14mm	ExtraScan II 14mm
入口光斑	Input Beam Aperture (mm)	14	14
光柱位移	Beam Displacement (mm)	16.42	16.42
跟随误差	Tracking Error (ms)	0.40	0.25
重复精度	Repeatability ( $\mu$ rad)	< 1	< 1
零位漂移	Offset Drift ( $\mu$ rad/K)	< 15	< 15
增益漂移	Gain Drift (ppm/K)	< 8	< 8
8小时以上漂移	Long-term drift over 8 hours (mrad)	< 0.1	< 0.08
1%全行程	1% of full scale (ms)	0.85	0.6
10%全行程	10% of full scale (ms)	1.80	1.50
定位速度	Positioning Speed (m/s)	5	7.0
扫描角度	Typical Scan Angle ( $^{\circ}$ )	$\pm 12.5$	$\pm 12.5$
增益误差	Gain Error (mrad)	< 5	< 5
零位误差	Zero Offset (mrad)	< 5	< 5
非线性度	Nonlinearity (%)	< 0.1	< 0.1
电源要求	Power Requirements	$\pm 15$ VDC, $\geq 3$ A	$\pm 15$ VDC, $\geq 3$ A
数字接口	Digital Interface	XY2-100	XY2-100
工作温度	Operation Temperature (C)	25 $\pm$ 10	25 $\pm$ 10
重量	Weight (kg)	2.3	2.3

### □ 外形尺寸图

TECHNICAL DRAWING

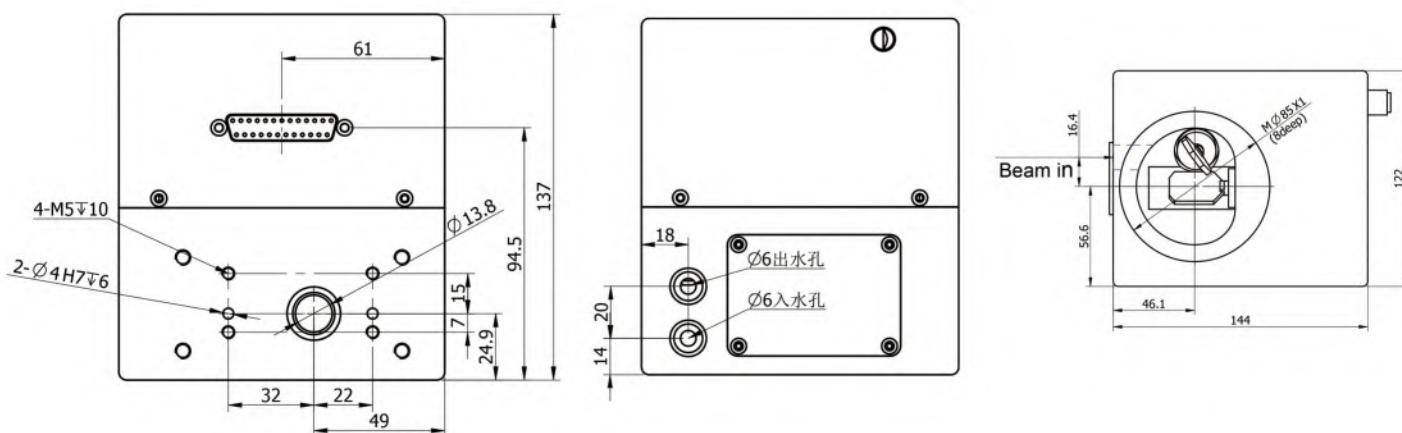



# EXTRASCAN 20MM

## 20mm光栅振镜



### □ 技术参数

TECHNICAL PARAMETERS

		ExtraScan I 20mm	ExtraScan II 20mm
入口光斑	Input Beam Aperture (mm)	20	20
光柱位移	Beam Displacement (mm)	25.25	25.25
跟随误差	Tracking Error (ms)	0.65	0.5
重复精度	Repeatability (μrad)	< 1	< 1
零位漂移	Offset Drift (μrad/K)	< 15	< 15
增益漂移	Gain Drift (ppm/K)	< 8	< 8
8小时以上漂移	Long-term drift over 8 hours (mrad)	< 0.1	< 0.08
1%全行程	1% of full scale (ms)	1	0.85
10%全行程	10% of full scale (ms)	3	2.60
定位速度	Positioning Speed (m/s)	3	5.0
扫描角度	Typical Scan Angle (°)	±12.5	±12.5
增益误差	Gain Error (mrad)	< 5	< 5
零位误差	Zero Offset (mrad)	< 5	< 5
非线性度	Nonlinearity (%)	< 0.1	< 0.1
电源要求	Power Requirements	±15VDC, ≥3A	±15VDC, ≥3A
数字接口	Digital Interface	XY2-100	XY2-100
工作温度	Operation Temperature (°C)	25±10	25±10
重量	Weight (kg)	5.0	5.0

### □ 外形尺寸图

TECHNICAL DRAWING

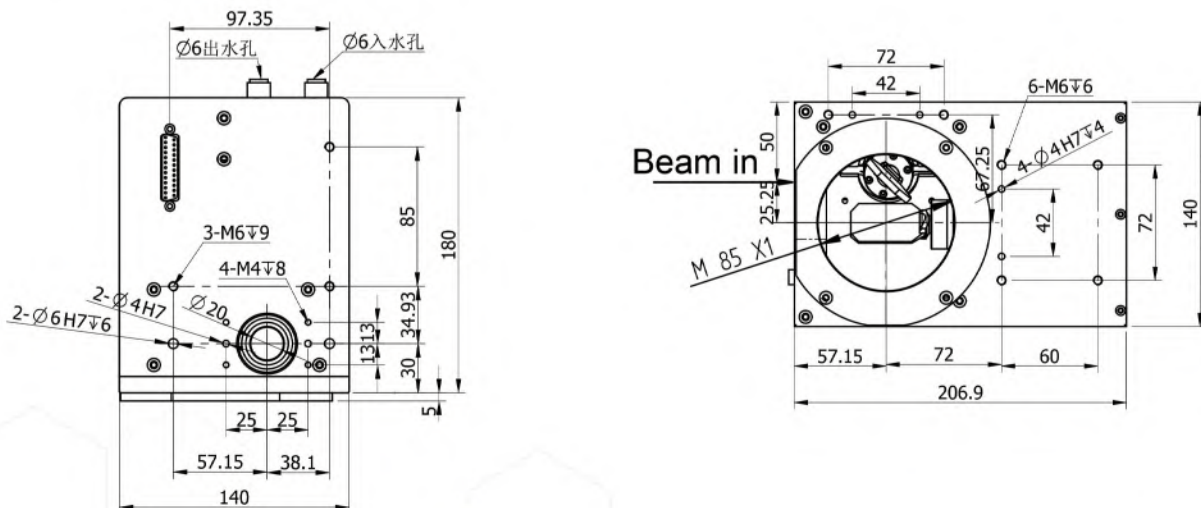

# EXTRASCAN 30MM

## 30mm光栅振镜



### □ 技术参数

TECHNICAL PARAMETERS

		ExtraScan I 30mm	ExtraScan II 30mm
入口光斑	Input Beam Aperture (mm)	30	30
光柱位移	Beam Displacement (mm)	35.53	35.53
跟随误差	Tracking Error (ms)	1.2	0.80
重复精度	Repeatability ( $\mu$ rad)	< 1	< 1
零位漂移	Offset Drift ( $\mu$ rad/K)	< 15	< 15
增益漂移	Gain Drift (ppm/K)	< 8	< 8
8小时以上漂移	Long-term drift over 8 hours (mrad)	< 0.1	< 0.08
1%全行程	1% of full scale (ms)	1.50	1.30
10%全行程	10% of full scale (ms)	5	4.80
定位速度	Positioning Speed (m/s)	2	3.0
扫描角度	Typical Scan Angle ( $^{\circ}$ )	$\pm 12.5$	$\pm 12.5$
增益误差	Gain Error (mrad)	< 5	< 5
零位误差	Zero Offset (mrad)	< 5	< 5
非线性度	Nonlinearity (%)	< 0.1	< 0.1
电源要求	Power Requirements	$\pm 15$ VDC, $\geq 3$ A	$\pm 15$ VDC, $\geq 3$ A
数字接口	Digital Interface	XY2-100	XY2-100
工作温度	Operation Temperature ( $^{\circ}$ C)	25 $\pm$ 10	25 $\pm$ 10
重量	Weight (kg)	5.2	5.2

### □ 外形尺寸图

TECHNICAL DRAWING

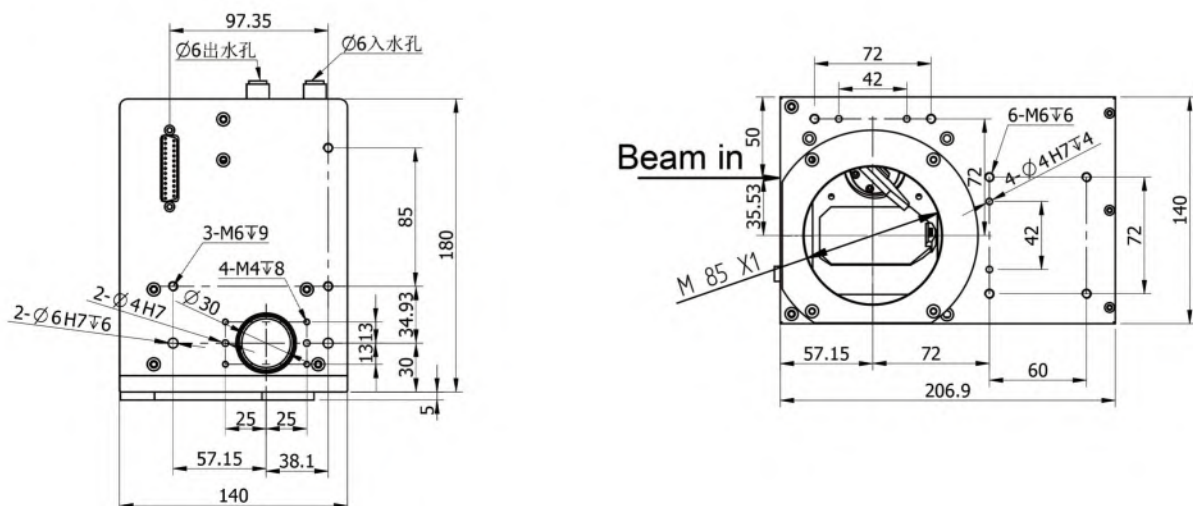



# INTELLIGENT INTEGRATED SCANNING SYSTEM

## 智能一体扫描系统

### 产品特点 FEATURES



使用方便，无需安装控制卡驱动程序。  
Easy to use without the extra installed control card.



线材制作简单，可靠性高。  
Simplify wire production with high reliability.



实现了振镜和激光器的同步实时控制。  
Simultaneously real-time control of galvanometer and laser.



可实现局域网内的远程控制，支持SD卡存储，可实现脱机打标。  
Remotely control in LAN, Support SD card storage and offline marking.

### 产品组成 PRODUCT COMPOSITION

#### ● 激光加工扫描头 (Laser processing head)

采用双核ARM架构，主频800MHz，配备512MB DDR3内存，板载256 Mbit。

Adopt dual-core ARM architecture and dominant Frequency 800MHz, equipping with 512MB DDR3 memory and onboard 256 Mbit.

#### ● 激光打标软件 (Laser marking software)

具有高精度BOX校正功能，校正精度可达6 $\mu$ m，同时支持3D焦点校正功能。

High-precision BOX correction function with calibration precision up to 6 $\mu$ m and support 3D focus calibration.

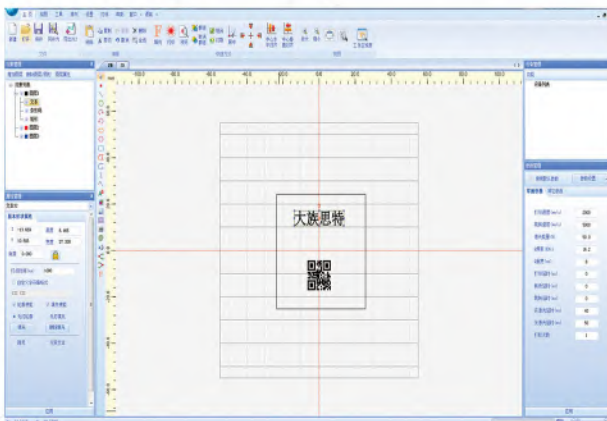

二维界面  
2D Interface

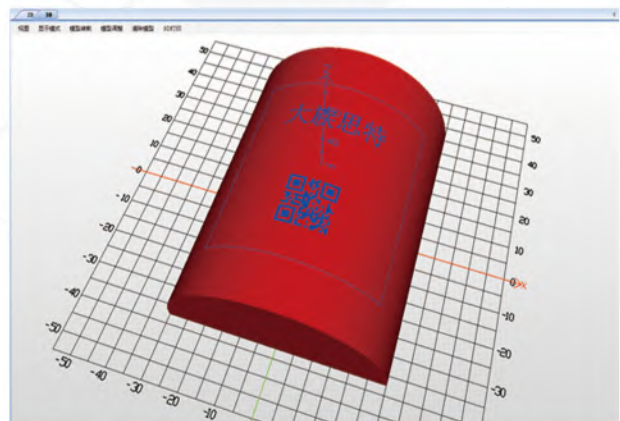

三维界面  
3D Interface



# HASHUSCAN 10MM



## □ 技术参数

TECHNICAL PARAMETERS

		HaShuScan 10mm	HaShuScan 14mm
入口光斑	Input Beam Aperture (mm)	10	14
光柱位移	Beam Displacement (mm)	12.54	16.42
跟随误差	Tracking Error (ms)	0.18	0.30
重复精度	Repeatability (μrad)	< 2	< 2
零位漂移	Offset Drift (μrad/K)	< 15	< 15
增益漂移	Gain Drift (ppm/K)	< 80	< 80
8小时以上漂移	Long-term drift over 8 hours (mrad)	< 0.3	< 0.3
1%全行程	1% of full scale (ms)	0.40	0.65
10%全行程	10% of full scale (ms)	1.20	1.60
定位速度	Positioning Speed (m/s)	10.0	7.0
扫描角度	Typical Scan Angle (°)	±12.5	±12.5
增益误差	Gain Error (mrad)	< 5	< 5
零位误差	Zero Offset (mrad)	< 5	< 5
非线性度	Nonlinearity (%)	< 0.4	< 0.4
电源要求	Power Requirements	±15VDC, ≥3A	±15VDC, ≥3A
工作温度	Operation Temperature (°C)	25±10	25±10
重量	Weight (kg)	1.9	2.3

## □ 外形尺寸图

TECHNICAL DRAWING

HaShuScan 10mm

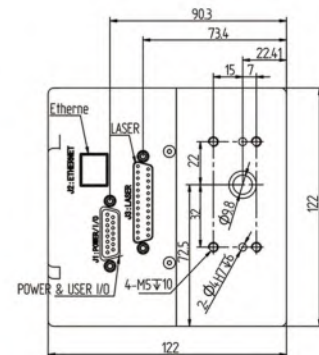
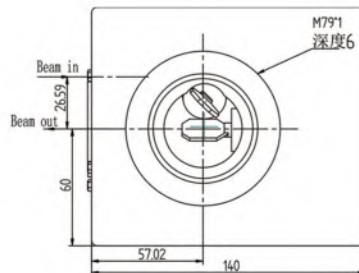

HaShuScan 14mm

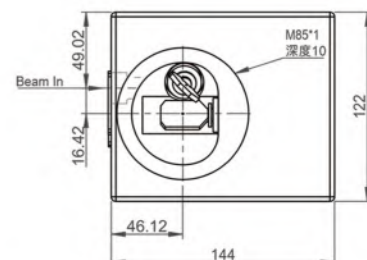
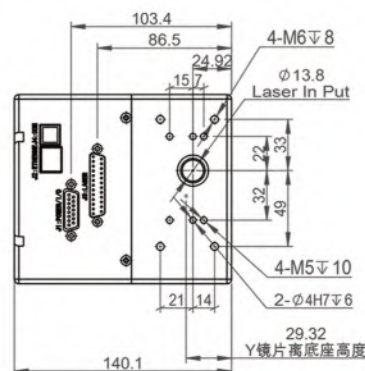

# HIGH POWER GALVANOMETER WELDING SYSTEM

## 高功率振镜焊接系统

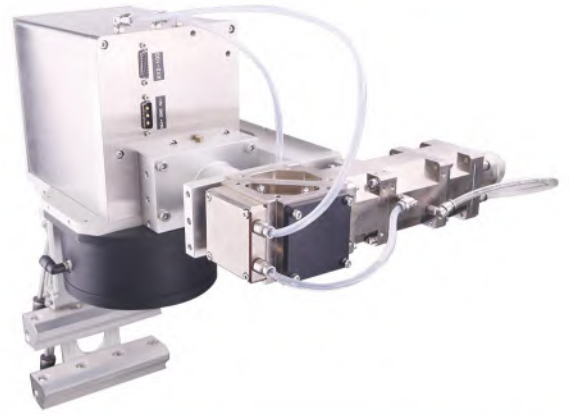

### 产品特点

#### FEATURES



采用高精度高速度的数字光栅振镜，焊接速度可达3000mm/s。

Adopt high precision and high speed digital grating galvanometer, welding speed up to 3000mm/s.



采用闭环控制系统，时刻监控振镜位置状态。

Adopt closed-loop control system to monitor the position and status of the galvanometer at any time.



采用高级别的系统安全机制，可10ms内关掉激光。

Adopt high level system safety mechanism, can turn off laser within 10ms.



拥有水冷、气冷双系统，和高端厚重的机柜。

With water cooling and air cooling system. With high-end and dignified cabinet.



具有多种摇摆功能：波浪形轨迹、螺旋线轨迹、8轨迹、∞轨迹。

With a variety of swing functions: wave-shaped trajectory, spiral trajectory, 8 trajectory and ∞ trajectory.



自主设计上位机软件，有能量波形、摆动功能、焊接参数等功能，具有调试、自动焊接模式。

Independent design PC software, It sets energy waveform, swing function, welding parameters, with debugging mode and automatic welding mode simultaneously.

### 技术参数

#### TECHNICAL PARAMETERS

		雷霆 Thunder 6000	雷霆 Thunder 3000
最大激光功率	Maximum Laser Power (kw)	6	3
激光波长	Laser Wavelength (nm)	1070±10	
场镜有效焦距	F-theta Lens Effective Focal Length (mm)	460	
焊接范围	Welding Range (mm)	220×220	
工作高度	Operating Height (mm)	565	
准直器有效焦距	Collimator Effective Focal Length (mm)	150 (可配其它尺寸 etc...)	
光纤连接方式	Fiber Connection Method	QBH	
通光孔径	Clear Aperture (mm)	30	
最大焊接速度	Maximum Welding Speed (mm/s)	3000	
工作温度	Operating Temperature (°C)	25±10	
重量	Weight (kg)	20	





## □ 上位机软件界面

SOFTWARE INTERFACE

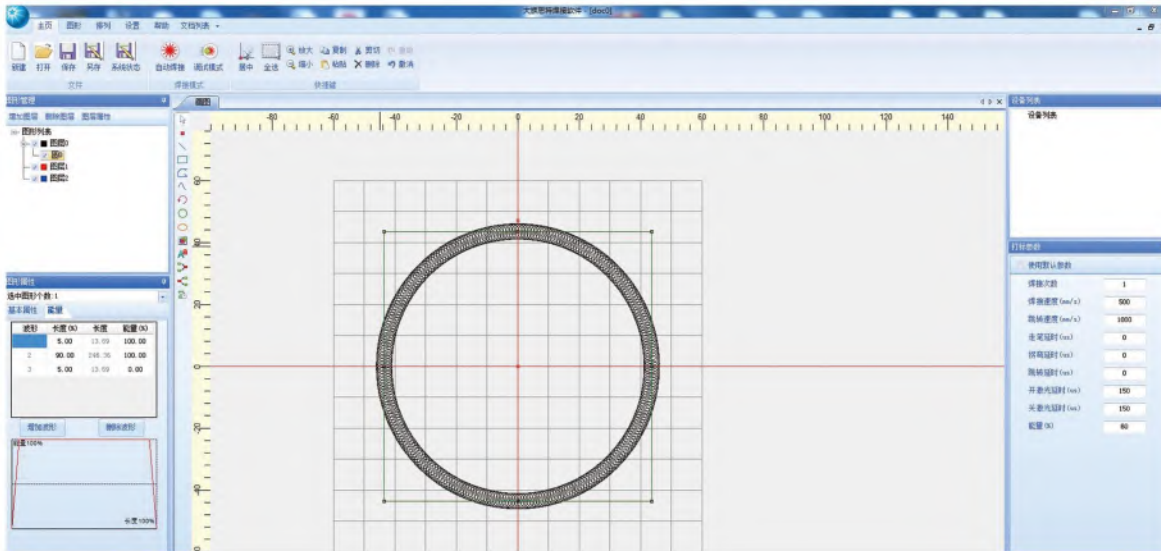

## □ 外形尺寸图

TECHNICAL DRAWING

高功率焊接振镜外形安装尺寸  
Installation dimension of high power welding galvanometer

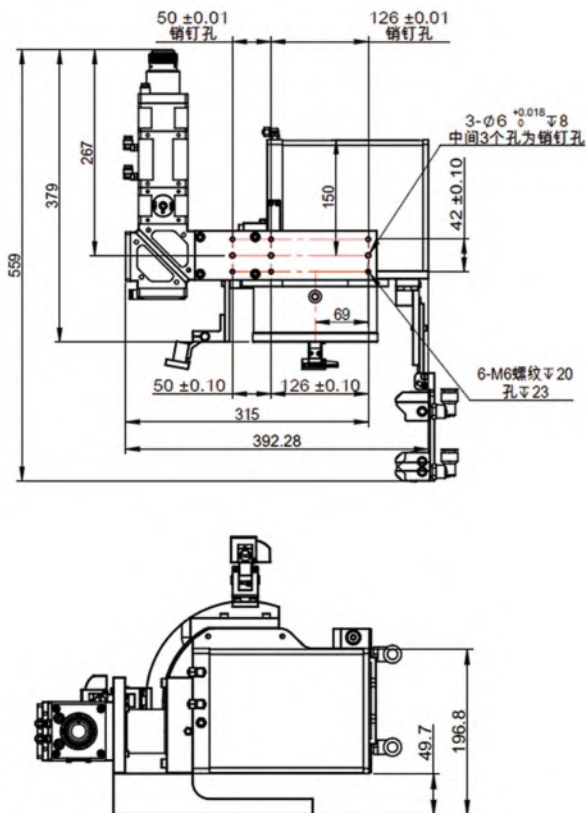

机柜外形尺寸图  
Technical drawing of cabinet

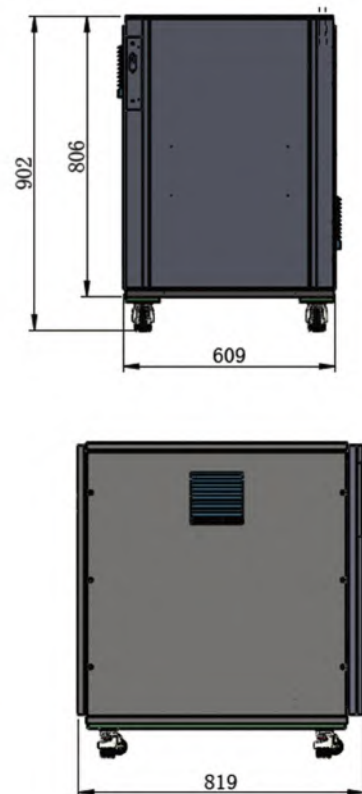



# VOICE MOTOR

## 音圈电机

### 产品特点

FEATURES

- 

采用高精度的光栅编码器作为反馈，位置解析精度为25位。  
High-precision grating ruler as feedback with 25 bit for the position resolution.
- 

极低的噪声、极好的线性度和最低的漂移。  
Extremely low noises, excellent linearity and minimal drift.
- 

采用基于FPGA的数字处理驱动器技术，极好的抗干扰能力和优秀的动态性能。  
FPGA-based digital processing driver technology with excellent anti-interference ability and dynamic performance.
- 

能与扫描头结合组成3D模组，广泛用于3D打标、大幅面加工等激光标记应用。  
It is able to compose 3D module with galvanometer scanner and has been successfully used in laser marking applications such as 3D marking, large format processing, etc.

### 行业应用

INDUSTRY APPLICATIONS

能与扫描头结合组成3D模组，广泛用于3D打标、大幅面加工等激光标记应用，更可应用于超快速3D加工、微加工、曲面标记和深度雕刻。

It is able to compose 3D module with galvanometer scanner and has been successfully used in laser marking applications such as 3D marking, large format processing, etc. It can also be used in ultra fast 3D machining, micro machining, surface marking and depth carving.

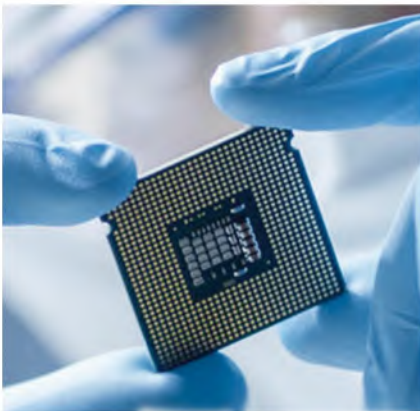

# VCM F1 & VCM Z & VCM G2



## □ 技术参数

TECHNICAL PARAMETERS

		VCM F1	VCM Z	VCM G2
入口光斑	Input Beam Aperture (mm)	20	14	≤22
出口光斑	Output Beam Aperture (mm)	40	14	/
行程	Stroke (mm)	≤20	±15 (Focus Range)	9
跟随误差	Tracking Error (ms)	0.7	≥0.15	1.5 (≤16mm镜片) 2.2 (18mm~22mm镜片)
典型速度	Typical Speed (mm/s)	≤180	/	≤100
调焦速度	Focus Speed (m/s)	/	up to 20m/s (F=160mm)	/
重复精度	Repeatability (μm)	< 0.5	< 1	< 1
非线性度	Nonlinearity (%)	0.05	0.4	2
8小时以上漂移	Long-term Drift over 8 hours (μm)	<3	< 6	<10
电源要求	Power Requirements	±15VDC, ≥3A	±15VDC, ≥3A	±15VDC, ≥3A
数字接口	Digital Interface	XY2-100	XY2-100	XY2-100
工作温度	Operation Temperature (°C)	25±10	25±10	25±10

## □ 外形尺寸图

TECHNICAL DRAWING

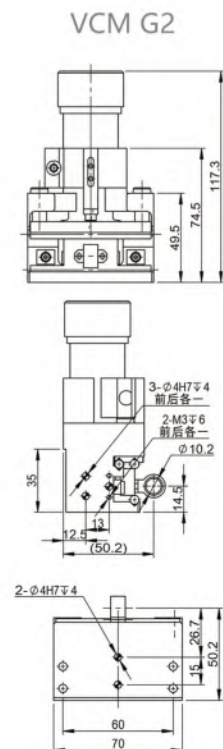
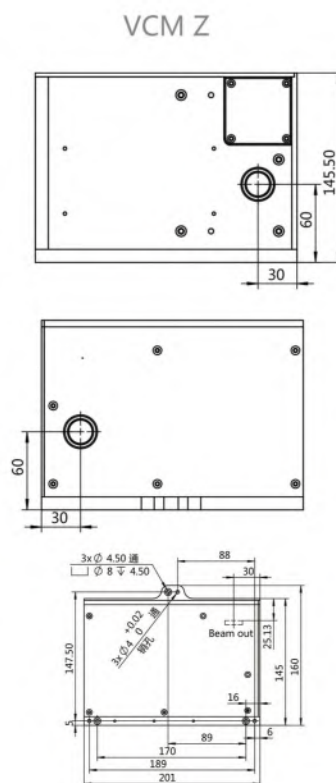
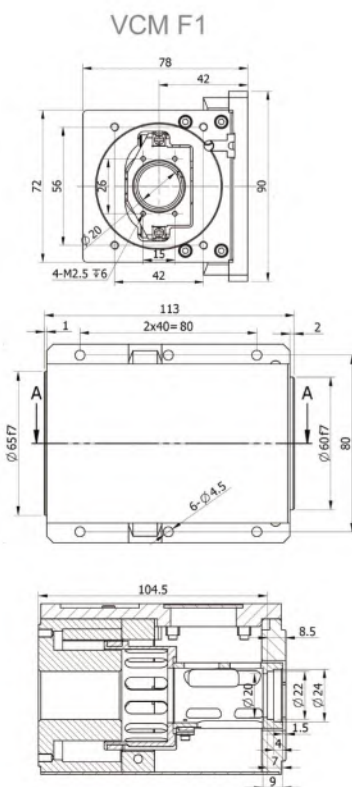



# 14MM 3D&2.5D SCANNING SYSTEM

## 14mm快速3D&14mm2.5D系统



### □ 技术参数

TECHNICAL PARAMETERS

#### 电源参数 Power Supply Parameter

输入电压	Input Voltage (VAC)	170-264
输出电压	Output Voltage (VDC)	±15
额定输出电流	Current (A)	10

#### 控制卡参数 Control Card

输出接口	Input Interface	XY2-100协议 Protocol
输入接口	Output Interface	网口 Ethernet Port
激光器控制	Laser Type	紫外、红外、绿光激光器 UV、IR、Green Laser

#### 环境要求 Environmental Requirement

工作温度	Ambient Temperature (°C)	0 ~ +40
存储温度	Storage Temperature (°C)	-10 ~ +60
湿度	Humidity	≤75%无凝结 Non-Condensing

#### 振镜参数 Galvanometer Parameters

工作偏转角	Scan Angle (°)	±11.5
重复标刻精度	Repeatability (urad)	5
最大增益漂移	Max.Gain Drift (ppm/K)	12
8小时长期漂移	Long-term Drift Over 8h (mrad)	0.3
最大位置漂移	Max.Offset Drift (urad/K)	30
最大加工速度	Maximal Processing Speed (字符/s)	650
小步长阶跃相应时间	Small Step Response (ms)	≤0.18

#### 动态变焦系统参数 Dynamic Zoom System Parameters

小步长阶跃相应时间	Small Step Response (ms)	≤1.6
-----------	--------------------------	------

#### 光学参数 Specifications For Optics

激光介质	Laser	UV Laser	IR	Green
波长	Wavelength (nm)	355	1064	532
镀膜	Coating	抗反射膜 Anti-Reflection Film		
振镜通光直径	Aperture Size (mm)	φ14		
系统入射光斑	System Input Laser Beam (mm)	9	7	3.5

#### 结构参数 Specifications For Structure

重量	Weight (Kg)	8
尺寸	Dimension (mm)	324x140x181.5



### 绿光2.5D系统 Green 2.5D System

波 长	Wavelength (nm)	532
振镜透光直径	Aperture Size (mm)	φ14
系统入射光斑	System Input Laser Beam (mm)	φ3.5
工 作 范 围	Field Size (mm)	70x70
Z 轴 聚 焦 范 围	Focus Range In Z-Direction (mm)	±5
场镜离工作面距离	Distance Of F-Theta From Working Face(mm)	93.03
最小光斑直径((基于光束质量M <sup>2</sup> =1))	The Smallest Spot diameter1/e <sup>2</sup> (mm)	0.01

### 红外2.5D系统 IR 2.5D System

波 长	Wavelength (nm)	1064
振镜透光直径	Aperture Size (mm)	φ14
系统入射光斑	System Input Laser Beam (mm)	7
工 作 范 围	Field Size (mm)	210*210
Z 轴 聚 焦 范 围	Focus Range In Z-Direction (mm)	±20
场镜离工作面距离	Distance Of F-Theta From Working Face(mm)	330
最小光斑直径((基于光束质量M <sup>2</sup> =1))	The Smallest Spot diameter1/e <sup>2</sup> (um)	45

### 紫外3D系统 UV 3D System

工作范围	Field Size (mm)	100x100x40	200x200x80	300x300x150	400x400x150	500x500x150	600x600x150
最小光斑直径	The Smallest Spot Diameter1/e <sup>2</sup> (mm)	0.009	0.015	0.022	0.026	0.033	0.039

### 绿光3D系统 Green 3D System

工作范围	Field Size (mm)	100x100x40	200x200x80	300x300x150	400x400x150	500x500x150	600x600x150
最小光斑直径	The Smallest Spot Diameter1/e <sup>2</sup> (mm)	0.013	0.023	0.031	0.04	0.0496	0.059

### 红外3D系统 IR 3D System

工作范围	Field Size (mm)	60x60x60	100x100x90	100x100x40	200x200x80
最小光斑直径	The Smallest Spot Diameter1/e <sup>2</sup> (mm)	0.021	0.027	0.025	0.0415

## 外形尺寸图

TECHNICAL DRAWING

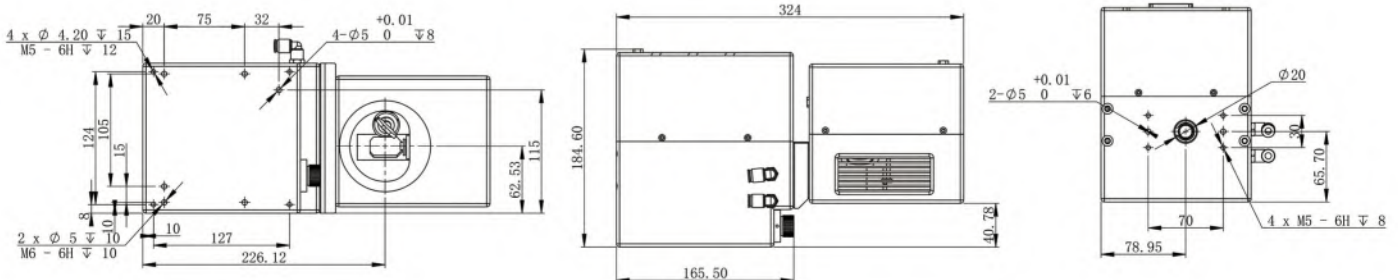

# 3D LARGE FIELD SIZE DYNAMICS FOCUSING SYSTEM

## 三维大幅面动态调焦系统

### 产品特点

FEATURES

- 

利用振镜电机和音圈电机的组合，实现三维曲面及大幅面的快速扫描。  
The combination of galvanometer and voice coil motor is used to realize the fast scanning of 3D curved surface and large format.
- 

系统集成度高，安装及使用简便。  
Highly integration system and easy to install and operate.
- 

与电脑通信采用TCP/IP通信协议，可实现1台电脑对多台系统的控制。  
Connected with computer through TCP/IP communication protocol, multiple scanner systems can be controlled by single one controller computer simultaneously.
- 

光路设计中考虑了不同幅面的激光聚焦效果，在工作范围内实现最小激光光斑点，能量更为集中。  
When design the optical path, considering the focusing effect under the different format, ensure the minimum laser spot within the working range in order to focus the energy.

### 行业应用

INDUSTRY APPLICATIONS

利用振镜电机和音圈电机的组合，实现三维曲面及大幅面的快速扫描，广泛用于较大幅面的激光精密标刻、激光浮雕、激光深雕、激光切割、激光焊接等高端加工领域。

The combination of galvanometer and voice coil motor is used to realize the fast scanning of 3D curved surface and large format. It is widely used in large format laser precision marking, laser relief, laser deep carving, laser cutting, laser welding and other high-end processing fields.





# CO2 & ULTRAVIOLET & IR

## 二氧化碳&紫外&红外

### □ 技术参数

TECHNICAL PARAMETERS

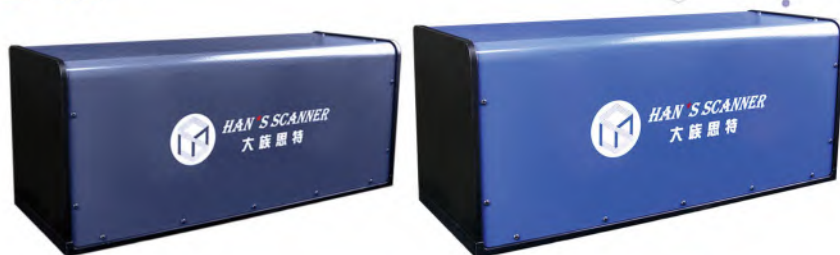

		CO2	紫外 Ultraviolet	红外 IR
电机摆动角度	Scan Angle (°)	±11	±11	±11
系统校正定位精度 System Emendation Orientation Accuracy		≤0.1mm (工作范围 Field Sizes≤800mm*800mm)		
重复标刻精度	Repeatability (urad)	2	5	2
最大增益漂移	Max.Gain Drift (ppm/k)	80	8	80
最大零位漂移	Max.Offset Drift(uRad/k)	15	15	15
8小时以上漂移	Long-term Drift Over 8 Hours (mrad)	≤0.3	≤0.1	≤0.3
跟随误差	Tracking Error (ms)	≤0.70	≤0.45	≤0.30/≤0.45/≤0.7
波长	Wavelength(nm)	10600	355	1064
入射光斑直径	Incident Spot Diameter (mm)	15	6	7/10
通光直径	Aperture Size (mm)	30	20	14/20/30
最大激光功率	Maximum Laser Power Cw(W/cm <sup>2</sup> )	1000	300	1500

CO2激光器配置实例		CONFIGURATION INSTANCE OF CO2 LASER			
工作范围	Field Size (mm*mm*mm)	最小光斑直径1/e <sup>2</sup>	The Smallest Spot Diameter1/e <sup>2</sup> (um)	工作距离	Working Distance (mm)
	100*100*0		181		96.5
	250*250*10		304		241.5
	500*500*150		568.2		550.5
	750*750*300		832		860.5
	1000*1000*500		1096		1169.5
	1250*1250*700		1360		1478.5
	1500*1500*900		1625		1788.5
	2000*2000*1400		2145		2407.5

紫外激光器配置实例		CONFIGURATION INSTANCE OF Ultraviolet LASER			
工作范围	Field Size (mm*mm*mm)	最小光斑直径1/e <sup>2</sup>	The Smallest Spot Diameter1/e <sup>2</sup> (um)	工作距离	Working Distance (mm)
	200*200*30		11		212
	300*300*50		15		309
	500*500*100		26		556
	700*700*150		34		804
	1000*1000*240		46		1175
	1200*1200*320		55		1423





14mm红外激光器配置实例		CONFIGURATION INSTANCE OF IR LASER (14mm)	
工作范围 Field Size (mm*mm*mm)	最小光斑直径1/e <sup>2</sup> The Smallest Spot Diameter1/e <sup>2</sup> (um)	工作距离 Working Distance (mm)	
200*200*40	45.2	177.4	
250*250*60	52.1	239.3	
300*300*80	60.7	301.2	
350*350*100	70	363.0	
400*400*120	79.3	425.0	

20mm红外激光器配置实例		CONFIGURATION INSTANCE OF IR LASER (20mm)	
工作范围 Field Size (mm*mm*mm)	最小光斑直径1/e <sup>2</sup> The Smallest Spot Diameter1/e <sup>2</sup> (um)	工作距离 Working Distance (mm)	
200*200*30	25.75	184.7	
400*400*70	49	432.2	
500*500*100	65	618.8	
600*600*120	77	679.7	
700*700*150	89	866.3	
800*800*180	101	927.2	
900*900*220	113	1113.8	
1000*1000*240	125	1174.7	
1200*1200*320	148.5	1422.2	

30mm红外激光器配置实例		CONFIGURATION INSTANCE OF IR LASER (30mm)	
工作范围 Field Size (mm*mm*mm)	最小光斑直径1/e <sup>2</sup> The Smallest Spot Diameter1/e <sup>2</sup> (um)	工作距离 Working Distance (mm)	
800*800*50	70	921.6	
1000*1000*200	84	1169.1	
1200*1200*450	100	1416.6	
1300*1300*550	108	1540.3	
1400*1400*700	116	1664.1	
1500*1500*850	124	1787.9	

外形尺寸图  
TECHNICAL DRAWING

紫外/20mm 红外  
Ultraviolet/20mm IR

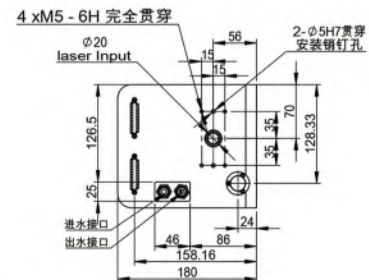
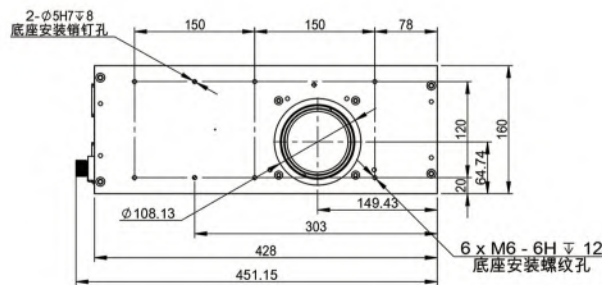

CO2/30mm 红外  
CO2/30mm IR

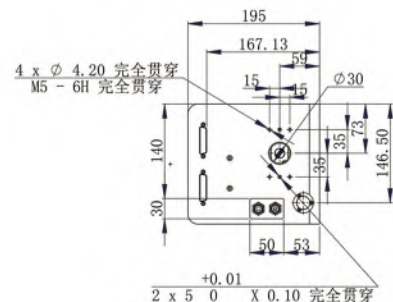
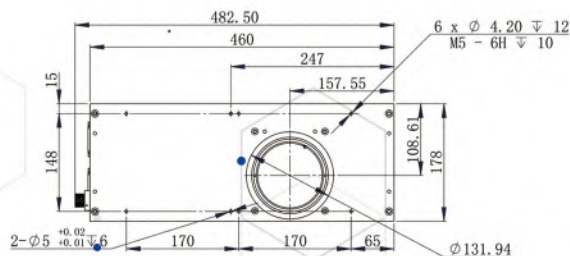

# FOUR-AXIS LINKAGE SYSTEM

## 四轴联动系统

### □ 工作原理

#### WORKING PRINCIPLE

四轴联动系统主要由XY振镜、XY运动平台、平台驱动器、GMC控制卡以及通用打标软件组成，拥有无限视野范围功能，可同步线性伺服轴与激光扫描振镜。当扫描振镜的高动态性能与伺服平台的大行程范围结合后，可连续处理比传统振镜更大的工作范围，无需进行工作区域的拼接。四轴联动系统不仅扩大了扫描振镜系统的工作范围及单个光学器件的应用范围，还避免了激光束范围与可用工作范围之间的相互影响，而且提高了加工质量和大型零件的生产。

The four-axis linkage system is mainly composed of XY galvanometers, XY motion platform, platform driver, GMC control card and general marking software. It has the function of unlimited field of vision, synchronize the linear servo shaft and laser scanning galvanometer. When the high dynamic performance of the scanning galvanometer is combined with the large stroke range of the servo platform, a larger working range can be continuously processed than that of the traditional galvanometer, without the need for stitching the working area. The four-axis linkage system not only expands the working range of the scanning galvanometer system and the application range of a single optical device, but also avoids the interaction between the laser beam range and the available working range, and improves the processing quality and the production of large parts.

### □ 产品特点

#### FEATURES



使用自主研发的GMC控制卡，系统可实现高速度、高精度、大幅面的激光加工。

Using GMC control card independently developed by Han's Scanner, the system can achieve high speed, high precision laser processing.



可导入标准格式的矢量图，也可进行二次开发，开发语言支持C++、C#。

Can import standard format vector graph, can also be secondary development, development language support C++, C#.



适用于大族思特系列扫描振镜，兼容XY2-100驱动的第三方振镜。

Suitable for Han's Scanner series scanning galvanometers, compatible with the other galvanometers driven by XY2-100.



只需要一张控制卡就可实现振镜与平台的实时同步联动控制。

Only one control card is needed to realize real-time synchronous linkage control between the galvanometer and the platform..





## 四轴联动方案组成

FOUR AXIS LINKAGE SYSTEM SCHEME



加工精度为5um@130mm行程  
The machining accuracy is 5um@130mm stroke

## 应用场景

APPLICATION SCENARIOS

- 大范围打标、切割、雕刻 Marking, cutting and engraving on a large scale.
- 微加工 Micromachining.
- OLED屏加工 OLED processing.
- 玻璃和箔片的加工 Glass and foil processing.
- 大面积PCB的钻孔 PCB large area drilling.

# 5 AXIS MICROMACHINING SYSTEM

## 五轴微加工系统



### 产品特点

FEATURES

普通激光钻孔系统只能加工锥孔，无法做到标准直孔和倒锥孔的加工。而5轴激光微加工系统，除了标准直孔，锥孔的加工以外，还能加工倒锥孔，极大的扩展了激光钻孔的应用。搭配不同波长及超快激光器，能做到钻孔热效应小，表面处理光滑等特点。才使加工材质无限制，真正应用到了各行各业的钻孔加工。

The ordinary laser drilling system can only process the taper hole, and can not achieve the standard straight hole and inverted cone hole processing. Besides the standard straight hole and the taper hole processing, the 5-axis laser micro machining system can also process the inverted cone hole, which greatly expands the application of laser drilling. With different wavelengths and super fast lasers, the thermal effect of drilling is small and the surface treatment is smooth. Only by making the processing materials unlimited, has been applied to drilling and processing in all walks of life.

### 技术参数

TECHNICAL PARAMETERS

五轴微加工系统 5 axis Micromachining System		
工作范围	Working Field Size (mm)	$\phi 0.025$ to $\phi 1$
Z方向最大变焦范围	Maximum Focus Range In Z Direction (mm)	$\pm 1$
系统入射光斑大小	Entrance Beam Diameter (1/e <sup>2</sup> ) (mm)	10
聚焦光斑大小(1/e <sup>2</sup> )M <sup>2</sup> =1	Focus Diameter In Image Field (1/e <sup>2</sup> ) for M <sup>2</sup> = 1 ( $\mu\text{m}$ )	25
最大进给角度	Maximum Angle Of Incidence (°)	18
旋进频率	Precession Frequency (HZ)	200-600 (12000-36000rpm)
物镜焦距	Objective Focal Length (mm)	50
重复精度	Repeatability ( $\mu\text{m}$ )	$\leq 0.5$
入射角的理论分辨率	Theoretical Resolution Of Incidence Angle (urad)	2
尺寸	Dimension (L*W*H) (mm)	601x280x274
重量	Weight (Kg)	23.5

### 应用场景

INDUSTRY APPLICATION

五轴微加工系统广泛应用于汽车工业（喷油嘴孔钻削），航空航天工业（涡轮叶片的冷却气膜孔），电子和电信行业，钟表行业，过滤行业，医疗技术行业（冠状动脉支架切割）。

Five axis micromachining system is widely used in automobile industry (drilling of nozzle hole), aerospace industry (cooling air film hole of turbine blade), electronics and telecommunication industry, clock industry, filtration industry, medical technology industry (coronary stent cutting).



# POLYGON SCAN HEAD

## 棱镜面扫描头



### 产品特点

FEATURES



高速性能。  
High speed.



高功率。  
High power.



低噪声、低漂移、高精度。  
Less noises, less drift, high-precision.



模板化设计，易于安装维护。  
Modular design, easy to install and maintain.

### 技术参数

TECHNICAL PARAMETERS

棱镜面扫描头 Polygon Scan Head		
入口光斑	Input Beam Aperture (mm)	≤15
波 长	Standard Wavelength (nm)	355/532/1064
扫描速度(线/秒)	Scan Speed (lines per second)	150-1600 (lines per second)
扫描线速度	Moving Spot Speed (m/s)	50-260 (f-theta=255)
线重复定位-Y轴	LINE Placement Repeatability-Y axis (urad)	±50
打标重复定位-X轴	Optimal Laser Pixel Placement Repeatability-X axis (urad)	±50
电源要求	Power Requirements	±15VDC@7Amax
扫描角度	Scan Angle (°)	±16 (X轴axis) , ±12.5 (Y轴axis)
工作温度	Operation Temperature (°C)	25±10

### 应用场景

INDUSTRY APPLICATION

棱镜面扫描可用于汽车雷达、激光清洗、激光打标、填充，玻璃和塑料的微钻孔和机械加工及3C行业电路板剥除覆盖膜等应用。

Polygon scan head can be used in automotive radar, laser cleaning, laser marking, filling, micro drilling and machining of glass and plastic, and peeling off the covering film of 3C industry circuit board.



## □ 接口定义

INTERFACE DEFINITION

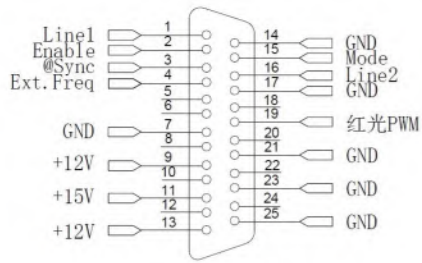

J1 DB25母头

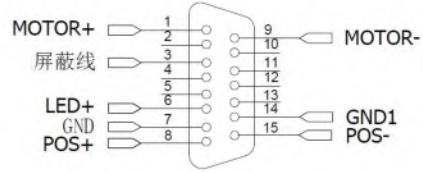

J3 DB15母头

## □ 外形尺寸图

TECHNICAL DRAWING

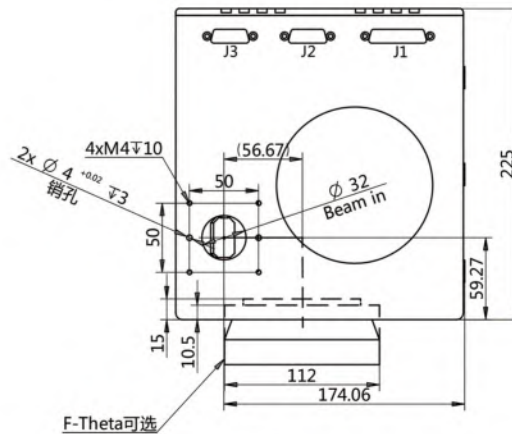
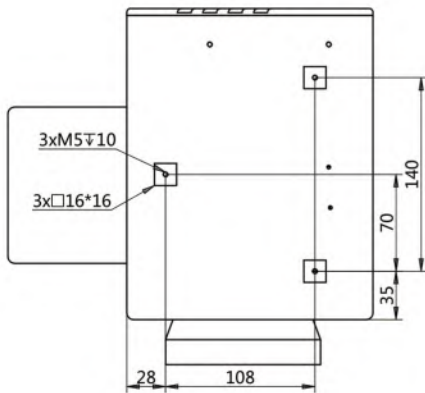
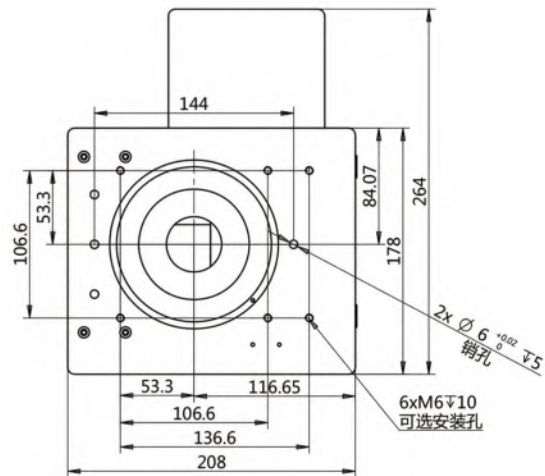
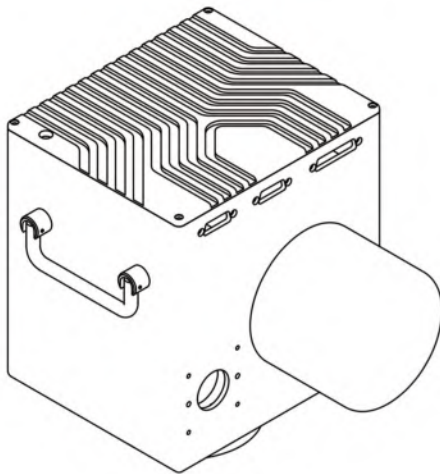



# OPTICAL COHERENCE TOMOGRAPHY SCAN

## 光学相干断层扫描

### 产品描述

#### PRODUCT DESCRIPTION

光学相干断层扫描（Optical Coherence Tomography Scan,简称OCT）技术是近年来新兴的一种测量技术，其通过检测发射光线与返回光线的光程差，得出探头到被测表面的相对距离，再经过一系列数学变换，即可形成一张包含实际物理距离信息的三维图像或二维图像。

Optical Coherence Tomography is a new technology in distance measurement area for recent years. The path length difference between the reference and measuring light paths is measured. Followed by a series of complex calculation, the 2D or 3D image can be produced by the device.

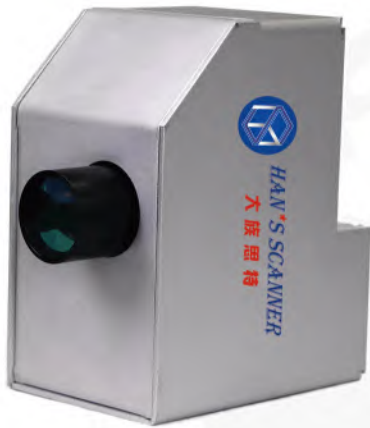

### 产品特点

#### FEATURES



具备深度信息测量能力，高度信息不受烟尘及颜色干扰。

Depth measurement for distance, Free from dust and color interference.



同时支持镜面与非镜面物体测量，且精度不因镜面损失。

Support mirror surface and non-specular measurement without precision loss.



支持透明物体透视测量。

Support transparent surface measurement.



无需辅助光源，不受环境光干扰。

Modular design, easy to install and maintain.

## □ 技术参数

### TECHNICAL PARAMETERS

OCT		
测量范围	Measuring Range (mm x mm)	40*40
测量深度	Measuring Depth (mm)	3
分辨率	Resolution (um)	X/Y方向 direction: 10 Z方向 direction: 6
测量速度	Measuring Speed (mm/s Max)	1600

## □ 行业应用

### INDUSTRY APPLICATIONS

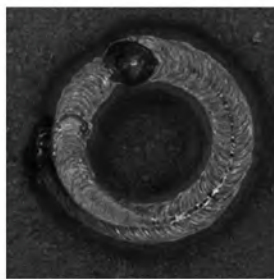

普通相机拍摄铜板焊接轨迹图  
Copper plate welding path photo taken by the normal industrial camera.

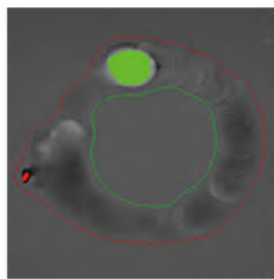

OCT检测, 无惧激光干扰  
Copper plate welding path photo taken by OCT. Free from laser interference.



普通相机拍摄铝板焊接轨迹图  
Aluminum plate welding path photo taken by the normal industrial camera.

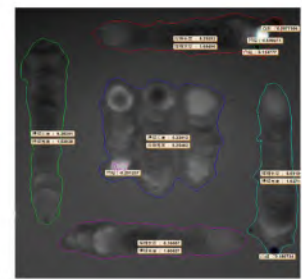

OCT设备自动扫描并计算  
Automatic scanning and calculation of OCT equipment.

OCT设备不仅自动完成焊缝识别, 同时对焊缝的长度, 宽度, 缺陷点高度和深度都进行了测算并显示。

Optical Coherence Tomography is a new technology in distance measurement area for recent years. The path length difference between the reference and measuring light paths is measured. Followed by a series of complex calculation, the 2D or 3D image can be produced by the device.

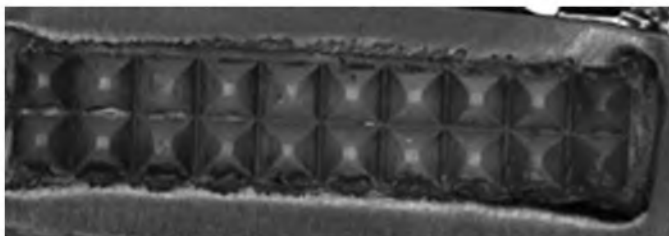

超声波焊缝图  
Ultrasonic welding joint photo taken by normal industrial camera.



OCT检测3D模型侧视图  
Ultrasonic welding joint photo taken by OCT with 3D image.



# MEDICAL BEAUTY FRACTIONAL GALVANOMETER

## 医疗美容点阵系统

### 产品特点

FEATURES

- 

操作界面友好，主要以图形选择和参数设置相结合的方式。  
User-friendly operation interface, mainly through the combination of graphic selection and parameter setting.
- 

多样化的治疗方案，包括美容点阵模式、妇科模式和手术切割模式。  
Diversified treatment options, including aesthetic fractional model, gynecological model and surgical excision model.
- 

采用数字/模拟系统，有多种报警功能和安全处理机制，确保设备的正常运行和安全使用。  
It adopts digital / analog system, and has multiple alarm functions and security processing mechanism to ensure the normal operation and safe use of the equipment.
- 

非顺序扫描模式，大幅度降低对周边组织的热损伤。  
Non-sequential scanning mode greatly reduces the thermal damage to surrounding tissues.
- 

手具电缆采用双层屏蔽机制，传输可靠，抗干扰能力强。  
Double-layer shield mechanism is adopted for handpiece cable, which is characterized by reliable transmission and strong anti-interference ability.
- 

操作界面友好，主要以图形选择和参数设置相结合的方式。  
User-friendly operation interface, mainly through the combination of graphic selection and parameter setting.

### 系统简介

SYSTEM INTRODUCTION

	控制系统 Control System	驱动器 Driver	人机交互界面 Interface	手具 Handpiece	备注 Remarks
数字系统 1 Digital system 1			 电容屏 10寸 Capacitive Screen 10 Inch	 HS1606	支持多种美容点阵模式 Support a variety of beauty dot matrix mode
数字系统 2 Digital system 2			 电阻屏 8/10.4寸 Resistive Screen 8/10.4 Inch	 HS1608	支持多种美容点阵模式 Support a variety of beauty dot matrix mode
模拟系统 Analog system			 电阻屏 8/10.4寸 Resistive Screen 8/10.4 Inch	 HS1608	只支持美容深层模式 Only support beauty deep mode



## □ 技术参数

### TECHNICAL PARAMETERS

		HS1606	HS1608
工作温度	Working Temperature (°C)	0 ~ 45	
非线性度	Nonlinearity (%)	<0.4	
小步阶响应时间	Setting Time (ms)	≤0.25	≤0.30
增益漂移	Gain Drift (PPM/°C)	<80	
零位漂移	Offset Drift (μRad /°C)	<15	
8小时以上漂移	Long-term drift over 8 hours (mrad)	<0.3	
平均工作电流	RMS Current (A)	0.65	
峰值电流	Peak Current (A (Max))	1.7	
最大扫描角度	Maximum Scan Angle (°)	±15	
存储温度	Storage Temperature (°C)	-10 ~ +50	
分辨率	Resolution (μrad)	8	
重复精度	Repeatability (μrad)	<5	
输入孔径	Input Aperture (mm)	5.0 ~ 7.0	
光束位移	Beam Displacement (mm)	10.7	
重量	Weight (g)	13	
频率	Frequency (Hz)	≤500 ※	

※ (输入指令为正弦波, 电机摆角±4°。 Input command is sine wave, motor swing angle ±4°)

## □ 外形尺寸图

### TECHNICAL DRAWING

HS1606

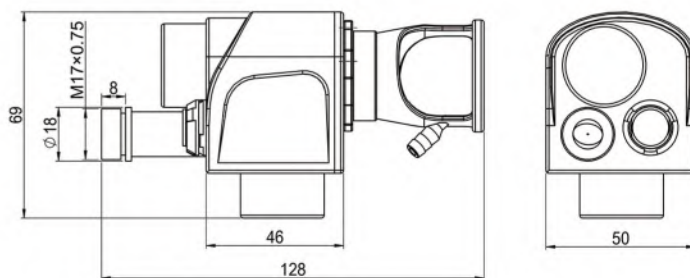

HS1608

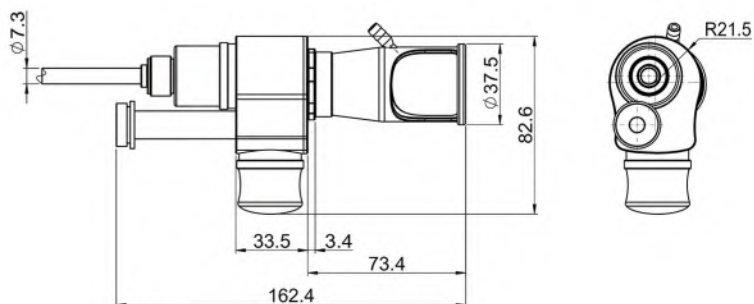





**深圳市大族思特科技有限公司**  
Shenzhen Han's Scanner S&T Co., Ltd.

总部地址: 广东省深圳市宝安区福永镇重庆路128号大族激光4栋4楼

Headquarters add: 4F Building4, Han's Laser Industry Park, 128 Chongqing Street, Fuyong, Bao'an District, Shenzhen City, Guang Dong, P.R. China.

华东办事处地址: 苏州市工业园区新平街388号腾飞创新园A1栋1111室

East China office add: room 1111, building A1, Tengfei Innovation Park, 388 Xinping street, Suzhou City.

电话TELL: 0755-2304 1055      网址Web: <http://www.hansscanner.com/>

邮箱Mail: [hansscanner@hanslaser.com](mailto:hansscanner@hanslaser.com)

